

CARATTERISTICHE TECNICHE	TECHNICAL FEATURES	CARACTERISTIQUE TECHNIQUE	DATOS TECNICOS	TECHNISCHE DATEN
<p><b>Motori Diesel</b> Kohler LDW 1003 3cyl. Kohler LDW 1404 4cyl. Kubota D1105 3cyl. Kubota V1505 4cyl.</p> <p><b>Trazione</b> Idrostatica su 2 oppure 4 ruote. A richiesta: motore idraulico a cilindrata variabile a comando elettrico.</p> <p><b>Cambio</b> Elettro-idraulico a 2 rapporti + Free Wheel</p> <p><b>Sterzo</b> Con idroguida sulle ruote anteriori • Sterzo indipendente sulle ruote posteriori (solo 4wd) • Con selettore a 3 posizioni indipendente e/o abbinato (a richiesta)</p> <p><b>Velocità</b> min 0 km/h max 13 km/h</p> <p><b>Freni</b> Idraulici sulle ruote posteriori. Freno negativo/stazionamento su 4 ruote. Idraulici su 4 ruote (a richiesta).</p> <p><b>Pedane raccogli frutta</b> Nr. 2 pedane anteriori ad apertura idraulica + Nr. 2 pedane posteriori ad apertura e sollevamento idraulico; (misure disponibili e corsa di sollevamento sono visibili nei disegni aclusi).</p> <p><b>Muletto anteriore</b> Idraulico per carico cassoni. Portata 500 kg.</p> <p><b>Muletto posteriore</b> Idraulico per scarico cassoni. Portata max 500 kg.</p> <p><b>Impianto per potatura</b> Compressore C.500/C.600 lt - innesto elettromagnetico, comando da cruscotto guida.</p> <p><b>Portata complessiva macchina q.li 60</b> I dati tecnici sono indicativi e non impegnativi.</p> <p><b>Ruota</b> 10,0/75x15,3 TM</p>	<p><b>Diesel Motor</b> Kohler LDW 1003 3cyl. Kohler LDW 1404 4cyl. Kubota D1105 3cyl. Kubota V1505 4cyl.</p> <p><b>Traction</b> Hydrostatic on 2 or 4 wheels. On request: hydraulic motor with variable cylinder capacity electrically controlled.</p> <p><b>Gears</b> 2 gears + Free Wheel - electro-hydraulic.</p> <p><b>Steering</b> Whit hydraulic power steering on the front wheels. Independent steering on the rear wheels (only 4 wd). With 3 positions selector independent and/or combined on request.</p> <p><b>Speed</b> min 0 km/h max 13 km/h</p> <p><b>Brakes</b> Hydraulic on the rear wheels. Parking/negative brake on 4 wheels. On request hydraulic brakes on 4 wheels.</p> <p><b>Fruit collector</b> Nr. 2 front platforms with hydraulic opening + Nr. 2 rear platforms with hydraulic opening and lifting (available size and vertical lift rails can be seen in the diagrams shown below).</p> <p><b>Front lift</b> Hydraulic lift for loading crates up to 500 kg capacity.</p> <p><b>Rear lift</b> Hydraulic lift for unloading crates up to 500 kg capacity.</p> <p><b>Pruning system</b> C.500/C.600 lt compressor -electromagnetic coupling, control on panel.</p> <p><b>Total capacity of the machine: 13,200 lbs.</b> The technical data are indicative and not binding.</p> <p><b>Wheel</b> 10,0/75x15,3 TM</p>	<p><b>Moteur Diesel</b> Kohler LDW 1003 3cyl. Kohler LDW 1404 4cyl. Kubota D1105 3cyl. Kubota V1505 4cyl.</p> <p><b>Traction</b> Hydrostatique sur 2 ou sur 4 roues. ur demande: moteur hydraulique à cylindrée variable avec commande électrique.</p> <p><b>Boîte de vitesses</b> À 2 Rapports + Free Wheel - électro-hydraulique.</p> <p><b>Direction</b> Avec hydroguide, sur les roues antérieures. Direction indépendante roues postérieures (seulement 4 wd). Avec sélecteur à 3 positions indépendante et/ou accouplé sur demande.</p> <p><b>Vitesse</b> min 0 km/h max 13 km/h</p> <p><b>Freins</b> Hydraulique sur les roues postérieures. Freins négatifs/stationnement sur 4 roues. Sur demande: freins hydrauliques sur les 4 roues.</p> <p><b>Tapis ramasse-fruit</b> Nr. 2 tapis avant avec ouverture hydraulique+Nr. 2 tapis arrière avec ouverture et levage hydrauliques (mesures disponibles et course de soulèvements sont visibles dans les dessins reportés ci-après).</p> <p><b>Chariot élévateur antérieur</b> Hydraulique pour chargement des caisses, portéè 500 Kg.</p> <p><b>Chariot élévateur postérieur</b> Hydraulique pour dechargement des caisses, portéè 500 Kg.</p> <p><b>Installation espalier:</b> Compresseur C500/C600 lt - branchement électro - magnétique, commande du tableau de bord conduite.</p> <p><b>Portée totale de la machine: 60 quintaux</b> Les caractéristiques ne sont données qu'à titre indicatif et ne créent pas d'engagements.</p> <p><b>Roue</b> 10,0/75x15,3 TM</p>	<p><b>Motores Diesel</b> Kohler LDW 1003 3cyl. Kohler LDW 1404 4cyl. Kubota D1105 3cyl. Kubota V1505 4cyl.</p> <p><b>Tracción</b> Hidrostática en 2 o en las 4 ruedas. Se puede solicitar motor hidráulico con cilindrada variable y dispositivo eléctrico.</p> <p><b>Caja de cambios</b> Con dos marchas + Free Wheel - electrohidráulico.</p> <p><b>Dirección</b> Hidráulica asistida en las rieda delanteras. Dispositivo independiente en las ruedas traseras (solo 4 wd). Se puede solicitar con selector de 3 posiciones independiente y/o combinado.</p> <p><b>Velocidad</b> mínima 0 km/h máxima 13 km/h</p> <p><b>Frenos</b> Hidráulicos en las ruedas traseras. Freno negativo/freno a mano en las 4 ruedas. Se puede solicitar el modelo con freno hidráulico en las 4 ruedas.</p> <p><b>Plataforma para la recolección de la fruta</b> Nº 2 reposapiés delanteros con apertura hidráulica + Nº 2 reposapiés traseros con apertura y elevación hidráulica (las medidas disponibles y las distintas capacidades de elevación se pueden apreciar en las imágenes que anexamos a continuación).</p> <p><b>Elevador delantero</b> Hidráulico para la carga de cajones, con una capacidad máxima de Kg 500.</p> <p><b>Elevador trasero</b> Hidráulico para la descarga de cajones, con una capacidad máxima de Kg 500.</p> <p><b>Equipo para poda</b> Compresor C500/C600 lt - con encendido electro - magnético, comandado desde el tablero de control del conductor.</p> <p><b>Capacidad total de la máquina: Ton 6</b> Datos tecnicos no empenados.</p> <p><b>Rueda</b> 10,0/75x15,3 TM</p>	<p><b>Dieselmotoren</b> Kohler LDW 1003 3cyl. Kohler LDW 1404 4cyl. Kubota D1105 3cyl. Kubota V1505 4cyl.</p> <p><b>Antrieb</b> Hydrostatisch auf 2 Rädern oder auf 4 Rädern. Auf Afrage: hydraulischer Motor mit variablem Hubraum und elektrischer Schaltung. Elektrischer antrieb</p> <p><b>Gangschaltung</b> 2 Gänge + Free Wheel - Gang-Elektrohydraulik</p> <p><b>Steuerung</b> Mit servolenkung auf den Vorderrädern. Unabhängige Steuerung der Hinterrädern (nur 4 wd). Mit unabhängigem und/oder kombiniertem 3 Positionsschalter als Extra</p> <p><b>Geschwindigkeiten</b> min 0 km/h max 13 km/h</p> <p><b>Bremsen</b> Hydraulische Bremsen auf den Hinterrädern. Negative Bremse/Parken auf 4 Rädern</p> <p><b>Hebebühne für das Obst</b> Nr. 2 vordere Fußstützen mit hydraulischer Öffnung + Nr. 2 hintere Fußstützen mit hydraulischer Öffnung und Anhebung (die zur Verfügung stehenden Maße und de Hebevorgan sind aus folgenden Zeichnungse ersichtlich).</p> <p><b>Vordere Hebevorrichtung</b> Hydraulisch beim Au_ aden der Kisten, Tragfähigkeit Kg. 500</p> <p><b>Hintere Hebevorrichtung</b> Hydraulisch beim Abladen der Kisten, Tragfähigkeit Kg. 500</p> <p><b>Schneidanlage</b> Kompressor C500/C600 l - elektromagnetisch. Einschaltung, Bedienung vom Armaturenbrett aus.</p> <p><b>Gesamtleistung der Maschine: 60 dz.</b> Die technischen Daten, sind nicht bindend.</p> <p><b>Rad</b> 10,0/75x15,3 TM</p>

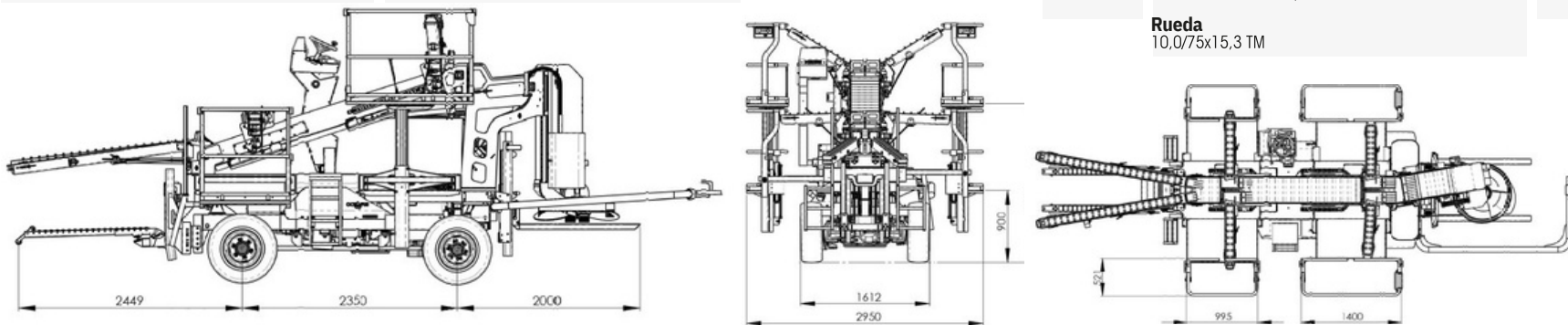

**N.BLOSI**  
ORCHARD PLATFORMS

Via G. Di Vittorio, 18  
48026 Russi (RA - ITALIA)  
Tel. +39 0544 583473 - Fax +39 0544 583214  
www.nblosi.com - e-mail: info@nblosi.com  
© Copyright Novembre 2019

# N.BLOSI<sup>TM</sup>

## ORCHARD PLATFORMS



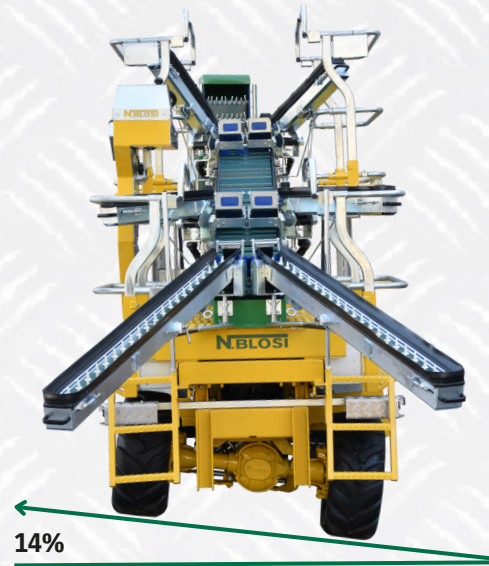

HEIGHT 900-1980



- 4 WHEEL STEERING
- SMALL TURNING RADIUS

